

Reducing the Short Circuit Levels in Kuwait Transmission Network. (A Case Study)

Mahmoud Gilany Wael Al-Hasawi
College of Technological Studies,
Kuwait

Abstract: Preliminary studies on Kuwait high voltage transmission system show significant increase in the short circuit level at some of the grid substations and some generating stations. This increase results from the growth in the power transmission systems in size and complexity. New generating stations are expected to be added to the system within the next few years. This paper describes the study analysis performed to evaluate the available and potential solutions to control SC levels in Kuwait power system. It also presents a modified planning of the transmission network in order to fulfill this task.

Keywords: Short circuit current, network splitting, fault current limiter, power transmission planning.

I. Introduction

The topography of the power system network keeps changing as the economy of a nation grows and its power consumption increases. One of the effects due to the growth of energy generation and the expansion of intermeshed transmission networks is the increase in short circuit currents in the power systems. These currents can cause mechanical and thermal stresses and they may damage the equipment. Consequently, the reduction and control of short circuit currents is a must.

The problem in Kuwait started at 2005 when a new emergency generation units were added to the network as a quick measure to avoid load shedding during heavy-load summer season. With the long term plan, new large generating stations are also expected to be installed. As a result, the short circuit level has increased and it is expected to highly increase in the near future.

One solution to reduce the risk of increasing short circuit levels in the power system is to upgrade the protection equipment so that the estimated fault currents are kept within the equipment capacity. This usually involves complete rebuilding of the substation. Nevertheless, this solution does not represent a high cost ratio benefit. It is an expensive solution, especially if primary and secondary breakers with their associated equipment are numerous. In addition to the cost, upgrading of the existing substations can be a

complicated process because of the number of equipment to be substituted, redesigned or tested [1].

Instead of upgrading the network, different techniques aiming at reducing the SC levels were examined, namely:

1. Change the neutral earth policy
2. Un-grounding cable sheath.
3. Changing some lines from AC to DC.
4. Apply current limiters.
5. Dividing the bus bars.
6. Splitting the network

This paper consolidates the experience of the Kuwait power utility with these measures. The study conclusions are presented in the form of power system operation strategy in order to maintain the fault currents within the permissible limits.

II. The Case Study

Kuwait transmission system consists of a 275 kV Grid supplied with three major generating stations with a capacity of approximately 6 GW as shown in Fig. 1. This network is connected to a 132 kV system which includes another 4 GW generating stations. Recently, the power system was connected via 400 kV tie-lines with Saudi Arabia as part of the Gulf network. Figure 1 is a simplified diagram of the 275 Kuwait power transmission systems.

Each bus in the Kuwait network is connected to 3 to 4 275/132 kV transformers. The network connected to the SSUR W 275/132 kV station shown in Fig. 2 is a typical example. Normally, the loops connected to any bus in the 132 kV networks are isolated from the loops connected to the other 132 kV busses. However, there are normally-open connections between these buses.

III. Analysis Study

For the purpose of examining the techniques to control the short circuit, the full Kuwait power network (275 and 132 kV) was implemented using a simulation program ASPEN-Oneliner V9.7 [2], which is a PC-based short circuit and relay coordination program widely used by protection engineers.

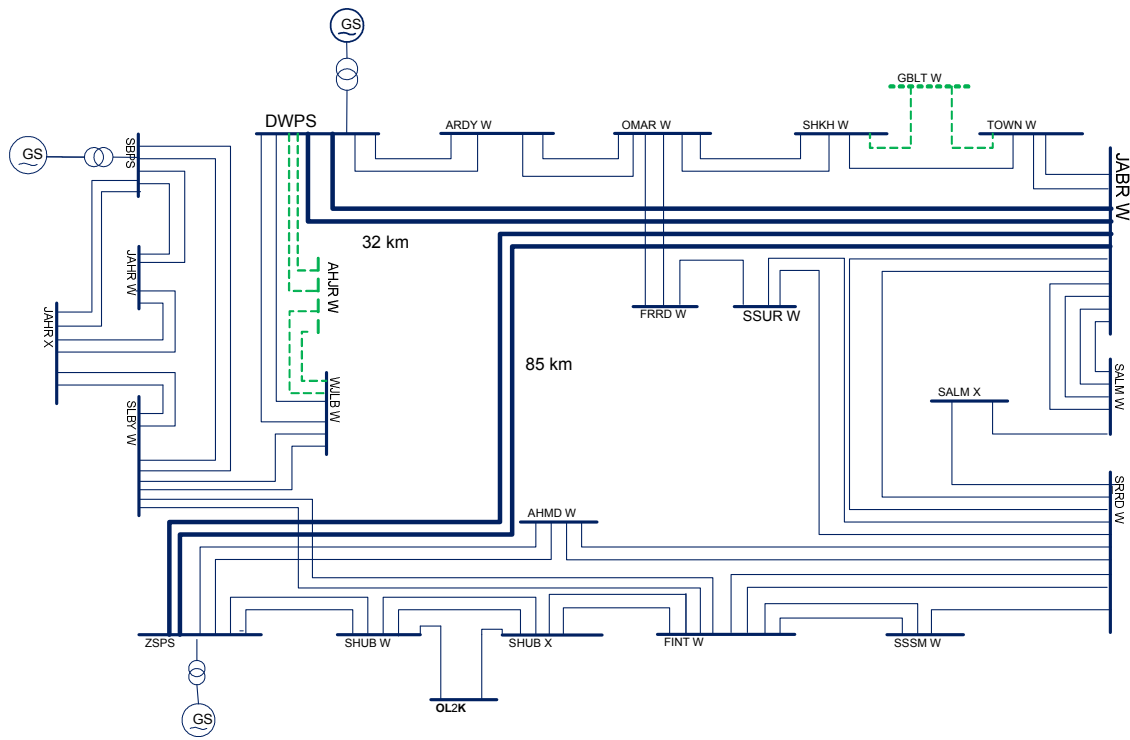

Fig. 1: The under study 275 kV transmission network

The short circuit level is examined at all the 275 and 132 kV stations. The simulation results show that the short circuit currents exceed the permissible levels in some specific points. It reaches 43 kA at some locations in the 132 kV networks where the nominal rupture capacity is 40 kA. The SC level also reaches 67 kA at some generating stations in the 275 kV networks where the rupture capacity is limited to 60 kA. A typical shape of the output results is shown in Fig. 3.

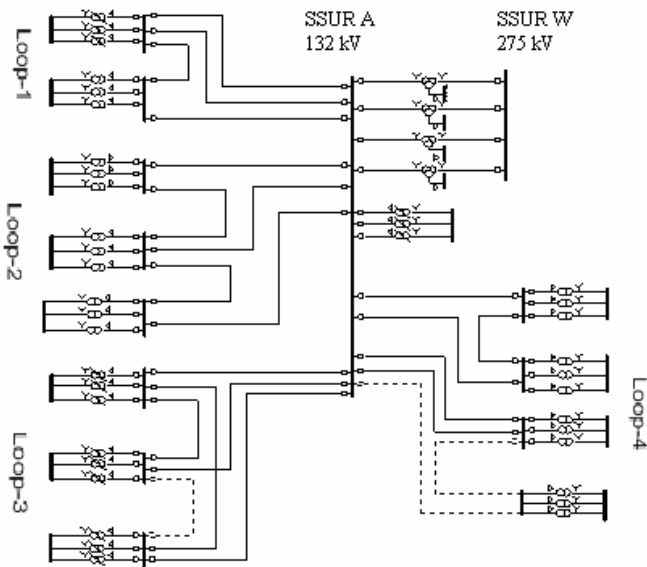

Fig. 2 Typical part of 132 kV network

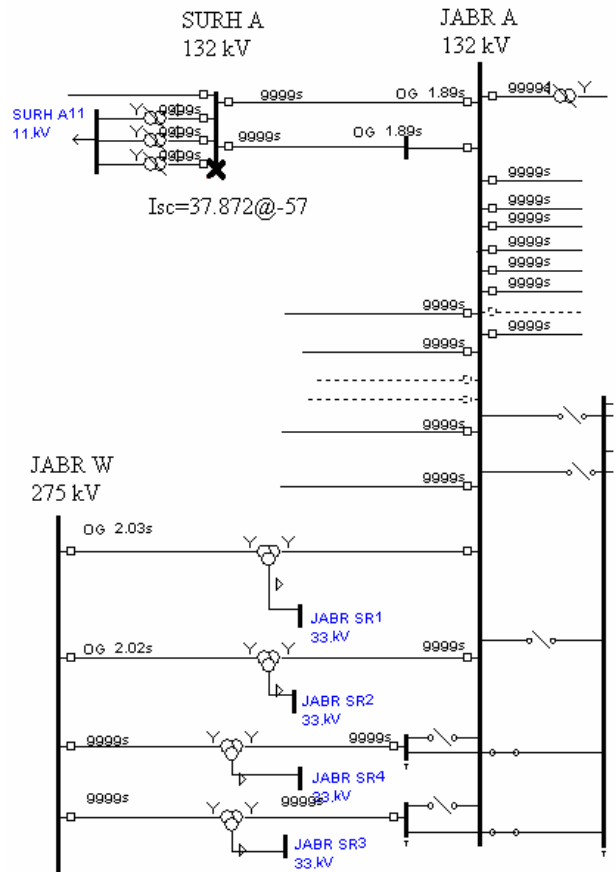

Fig. 3 A SLG fault at SURH A station

This figure shows only a part of the whole network. It represent a SLG fault applied at station SURH A (132 kV). The fault current exceeds 37 kA as shown in the figure.

These results did not take into consideration the expected new generation stations to be installed within the next few years. If the new generation is considered, the situation will be much more critical. Therefore, effective activities have to be planned with aim to reduce the high fault current levels and to avoid critical situations in the future.

In the remaining of this paper, the measures studied to limit fault currents are presented.

A. Changing the Neutral Earth Policy

Within Kuwait power stations, all the transformers (275 kV and 132kV) are solidly earthed. This type of earthing system was chosen to avoid any increase in the neutral voltage during earthing faults. However, the main disadvantage of such a system is the high magnitude of the short circuit currents. It was the right time to test the possibility of changing the earthing policy for some transformers from solidly earthing to earthing through small resistances.

The simulation results show that with 5Ω resistance inserted in the neutral of the local transformers at any substation, the short circuit level dropped by about 10%. It dropped to about 15% with 8Ω resistance. The drawbacks of this technique include the reduction in the sensitivity of the overcurrent relays. Practical considerations prevent the use of higher resistances. The measure has shown to have a limited effect on the SC reduction target.

B. Changing Some Lines from AC to DC

The idea of changing AC lines to DC lines starts as a result of the need to increase the power transfer capability of the existing transmission system without any major new construction. Conversion of an overhead AC lines to DC lines means changes in tower head, insulator assemblies and conductor configuration. There is no need to change the conductors, tower bodies, their foundations and there is no intermediate towers added [3, 4].

One of the main features of DC transmission is the fact that a HVDC connection contributes very little to the short circuit current. In fact, a back-to-back (BTB) dc connection functionally appears to be an open circuit from ac impedance point of view.

It can be seen from the structure of the 132 kV network under study shown in Fig. 2 that it consists of multiple loops connected to every 132kV bus-bar. Most of these feeders are short transmission lines. Consequently, it is neither practical nor economical to convert all the feeders of each loop to DC in order to reduce the SC level at this loop. Instead, the simulations studied the effect of changing some of the "key-

lines" especially those connecting major generation stations in the 275 kV network. For example, changing the two lines between DWPS and JABR W (see Fig. 1) from AC to DC will result in a reduction in the short circuit level at the stations supplied from JABR W power station by about 30%. For example, the SC level at station SURH A in Fig. 3 dropped from 37kA to about 22kA. Similarly, changing the two lines between ZSPS and JABR W station results in a reduction in the SC currents at station SURH A from 37 kA to about 23 kA. However, the high cost of the new equipment required (inverters and converters) and the short distances between most of the stations in Kuwait make this alternative inapplicable.

C. Applying Current Limiters

There is a high interest in fault current limiter as it reduces the expected SC current without affecting the steady state power flow. There are different techniques to reducing the short circuit levels using current limiters. The differences between these techniques include the type and location of different elements (reactor, thyristor controlled series inductor, superconductors, etc.) to limit the current. It also varies according to the network voltage level. The majority of the current limiters are installed in the tie circuits such as the bus tie and utility tie circuits in which the current limiters could perform effectively.

Figure 4 shows a short circuit problem found in the ZSPS station. This generating station consists of 8x300 steam generating units plus 4x80 MW gas turbine units. It has a 275 kV bus-bar with four normally-closed sections. The simulation results show that the SC current reached to a 67.3 kA at the station bus-bar. The rupture capacity is limited to only 63kA.

One of the most common solutions to the high level SC currents is the installation of air-core current limiting inductors (CLI). These CLI are usually installed, although not limited to, in tie buses and in series with the transmission line [5,6]. With a 5Ω reactor added in only one of the three tie-sections of the station, the short circuit level drops to about 52 kA.

The applicability of adding a reactor for such high voltage system is facing many problems [5]. Although these series reactors are the simplest and most economical means of achieving the reduction in the short circuit levels, stresses due to the high rate of rise of transient recovery voltages (TRV) and higher DC offset (X/R ratio) of the short-circuit current will be experienced by the associated circuit breakers. In addition, a high DC offset in the fault current may result in saturation of C.T. cores affecting the performance of the relay protection schemes [7].

The use of superconducting materials in the development of FCL looks promising, although at present costs are still too high. Superconducting materials are used for the reduction of fault currents, due to their unique characteristic of a fast transition from zero resistance at rated current to a finite value with greater current densities. This fast increase in the resistance results in a fast fault current limitation [8].

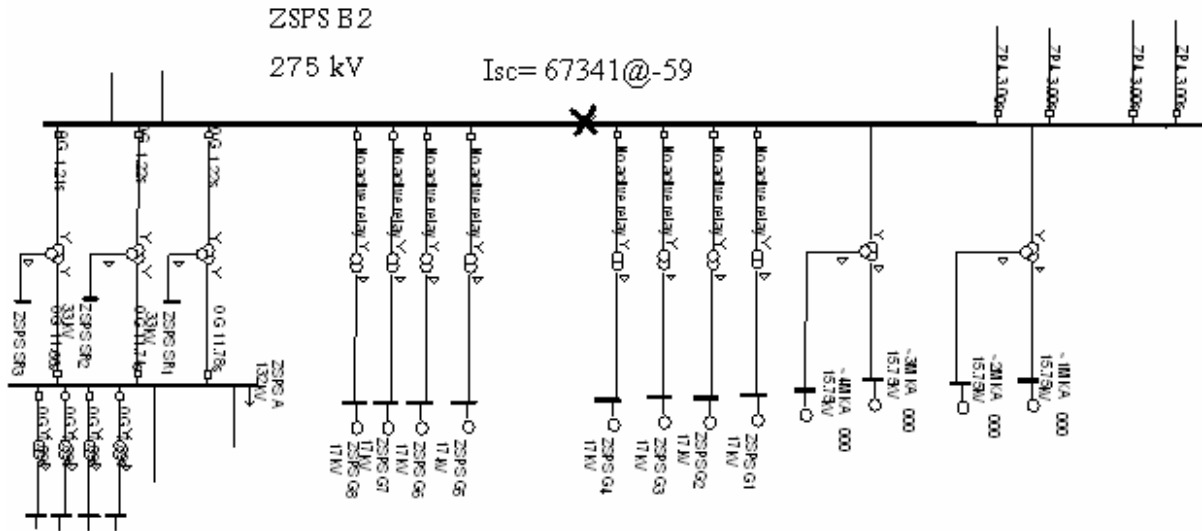

Fig. 4: A short circuit at a generating station

There are some other techniques adopting the concept of the current limiter e.g. series inductor- thyristor-controlled [9], the control regulates the average magnitude of the inductance and hence its current limiting effect. One of the disadvantages of this technique is the harmonic generation and the required use of filters.

D. Dividing the Bus Bar

Increasing the positive, negative, and zero sequence impedances seen by the fault, will result in reducing the short circuit currents. This is achieved in a substation by dividing buses in two or more sections. This solution is quite common and less expensive than upgrading circuit breakers. However, load division requires a careful study since the operating flexibility can be degraded in a significant manner. Also, the reliability can be affected as the number of transformers feeding the load is reduced.

In the system under study, this alternative was examined only at the 132 kV stations to avoid losing the system contingencies if applied on the BBs inside the generating stations. Even with the 132 kV stations, the application is limited to stations which have 4 275/132 kV transformers where the load can be divided equally inside the station. These conditions are not fulfilled in most of the stations.

E. Network Splitting

If the power system enters the emergency mode due to some disturbances, emergency controls will be applied to drive the system back to the alert mode. If the emergency controls fail to bring the system parameters back within their constraints, protective devices will act to prevent the power system components operating under unacceptable conditions

from undergoing damages [10, 11]. This may lead to system islanding, which often produces unstable or generation- load unbalanced islands. One quick solution is to temporarily split the power system

The most difficult part in the study of system splitting problem (SS problem) is to determine the proper splitting points (called splitting strategies) to split the entire interconnected transmission network into islands ensuring generation/load balance and satisfaction of transmission capacity constraints when islanding operation of the system is unavoidable. For a large-scale power system, the SS problem is very complicated in general. Moreover, network splitting presents a temporary (not guaranteed) solution to the developing SC problem.

IV. New Transmission Network Planning

The conclusions from the previous studies show that none of these techniques is perfect in solving the developed problem of increasing short circuit current levels. Taking into consideration that there are at least two new generating stations to be installed within few years, the optimum solution for the Kuwait network in solving the problem of the increasing SC levels is to construct a new higher voltage network (400 kV) and to connect all the new generating stations to this network. At the same time, the existing 275/132 kV network must be split permanently into three networks connected to the new 400 kV as shown in Fig. 5. The SCC, by this way, can be effectively reduced to acceptable levels.

To reach the above stated target, various network topologies are considered. The calculations performed include alternatively applied SCC, load flow and contingency analysis

for the proposed configuration in order to prove the technical requirements.

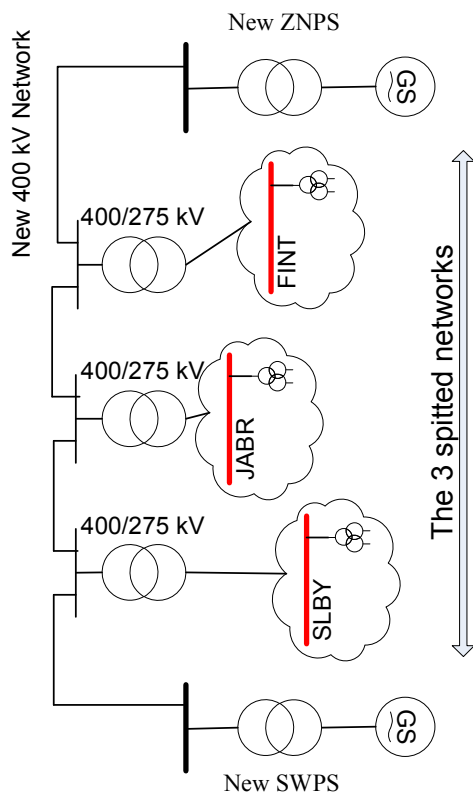

Fig. 5: The proposed power system

V. Conclusions

High level of fault currents is a normal consequence of transmission network expansion that follows the power system development. High fault levels require switchgear and other equipment with high rupture capacities. Reducing the fault level in a power system is cheaper alternative compared to the replacement of the switchgear. This paper presents different measures examined in order to control the high SC current at Kuwait high voltage network. Constructing a 400 kV high voltage network with a permanent Splitting of the existing 275 kV network, prove to be the most suitable solution for the highly increasing SC levels.

Acknowledgments

The financial support from the General Authority for Applied Education and Training in Kuwait (Project No. TS-02-08) is highly appreciated.

References

- [1] J. Panek, H. Elahi, "Substation Voltage Upgrading", IEEE Transactions on Power Delivery, Vol. 4, No. 3, July 1989, pp. 1715- 1724.
- [2] ASPEN-OneLiner Simulation Program.
- [3] H. Rahman and B. H. Khan, "Power Upgrading of Transmission Line by Combining AC–DC Transmission", IEEE Transactions on Power Systems, Vol. 22, No. 1, February 2007, pp. 459- 466.
- [4] Petersson, A., A. Edris, "Dynamic Performance of the Eagle Pass back-to-back HVDC Light Tie", 7th International conf on AC-DC Power Transmission, 2001, pp.220-225.
- [5] Alex Y. Wu, Yuexin Yin, " Fault Current Limiter Applications in Medium and High-Voltage Power Distribution Systems", IEEE Transactions on Industry applications, Vol. 34, No. 1, January/February 1998, pp. 236-242.
- [6] Mehrdad Tarafdar Haghl and Mehdi Abapour, "A New Topology of Fault-current Limiter and its control strategy", SICE-ICASE International Joint Conference, Oct. 18-21, 2006 , Bexco, Busan, Korea, pp. 5530-5534.
- [7] S. K. Lowe, "Circuit Breaker Stresses Associated with H.V. Series Reactors", Electrical Energy Conference, Australian Electrical Research, Canberra 10-12 May 1978, pp. 114-119.
- [8] K. Hongesombut, Y. Mitani, and K. Tsuji, "Optimal Location Assignment and Design of Superconducting Fault Current Limiters Applied to Loop Power Systems", IEEE Transactions on Applied Superconductivity, Vol. 13, No. 2, June, 2003 pp 1828-1831.
- [9] Parihar, P. G.G. Karady, "Characterization of a thyristor controlled reactor", Electric Power Systems Research, No.4, 1997, pp. 141-149.
- [10] Ming Jin, Tarlochan S. Sidhu, and Kai Sun, " A New System Splitting Scheme Based on the Unified Stability Control Framework", IEEE Transactions on Power Systems, Vol. 22, NO. 1, Feb. 2007, pp. 433-441.
- [11] Kai Sun, Da-Zhong Zheng, and Qiang Lu, "Splitting Strategies for Islanding Operation of Large-Scale Power Systems Using OBDD-Based Methods", IEEE Trans. on Power Systems, Vol. 18, No. 2, May 2003, pp. 912-923.